



Granular/Liquid Automatic Spreader Control (GL400)

- State of the art micro-processor design
- New anti-ice features
- Advanced data management capabilities
- Open-loop or closed-loop operation
- Easy to use backlit controls
- Large LCD dot matrix display
- Windows menu based programming
- Your choice of 4 materials
- Advanced troubleshooting features
- Automatic gate height calibration
- Hydraulic and Electrically driven liquid pre-wet control
- GPS and Data management ready



The StormGuard GL400 is the one control that does it all! Whether it's granular, prewet, anti-icing, or all three at the same time, you can rely on the GL400 to assist in all aspects of your business including management, operators, and maintenance technicians. You get accurate control of granular and liquid materials as well as measurement and reporting capabilities. All of this in a competitively priced package. Your operators will appreciate the ease of control making long hours on the road safer and more productive. The "Windows" style menus for ease of calibration and self diagnostics will keep your technicians smiling. Another innovative solution from StormGuard, the leader in Snow & Ice control equipment.

"We Know Snow"

Specifications:

Battery Voltage:

10-32 VDC, with reverse polarity protection

Display:

64 x 128 graphic backlit display

Memory:

Calibration and data storage non-volatile

Communication:

RS-232

Inputs:

7 digital, 1 Multi Purpose

Outputs:

2 Digital
4 high power 3 amp max. per ch. PWM control outputs with short circuit protection

Temperature Range (controlled):

-4°F to 158°F (-20° C to 70° C) storage and operation

Additional Features:

- Closed-loop spinner option
- Anti-Ice control feature
- RS232 Communication Port

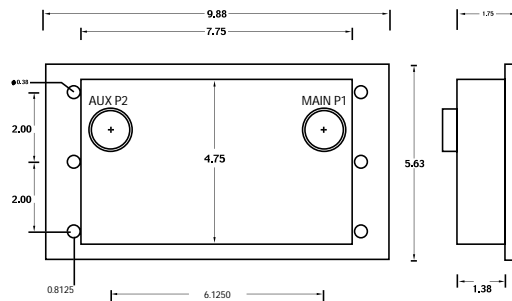
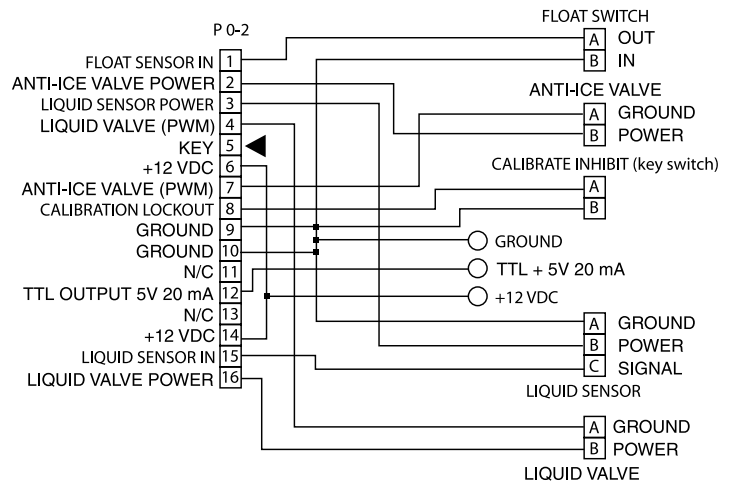
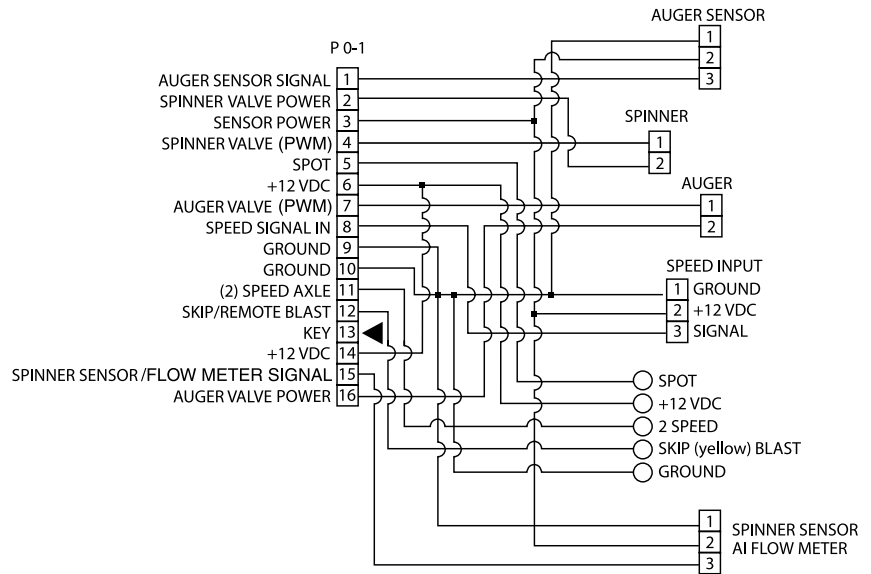

Complete cable sets are available as per system requirements. For more detailed product information, please contact your local dealer.

Starting A Revolution!

SG0102000501 NBC 7/03 2.5K

Distributed by:

Des Moines, IA (800) 333-7411
 Minneapolis, MN (800) 888-7411
 Mundelein, IL (888) 905-7411

Perrysburg, OH (800) 374-7411
 St. Louis, MO (800) 999-7411

or call our corporate headquarters for a location near you

Component Technology

A DIVISION OF
 Certified Power Inc.

phone: 847-573-3818
 fax: 847-573-3836

www.certifiedpower.com