



ML-100  
OPERATIONS MANUAL

PART NUMBER: SG07230010  
REV: A

**Component Technology**  
A DIVISION OF  
 **Certified Power Inc.**

# COMPONENT TECHNOLOGY

## ML-100

### INSTALLATION PROCEDURE

- Mount the ML-100 unit
- Connect the WIRING HARNESS
- Make sure power switch on the ML-100 is in the OFF (down) position
- Connect the 9-Pin connector to the back of the ML-100

### OPERATION PROCEDURE

The ML-100 has only two user accessible controls: the power switch and the application rate control. When the power switch is moved to the ON (up) position the amber backlight for the application rate control will be illuminated. The power switch affects the internal circuitry as well as voltages to the valve. The application rate control adjusts the drive to the valve. Depending on the configuration, the lowest application rate setting (fully counter clockwise) may be an OFF condition or the minimum preset drive level. The highest application rate (fully clockwise) will be at the maximum preset drive level. A LOW LEVEL condition is indicated by the red LED.

### CHANGING PRESET SETTINGS

- Necessary Equipment
  - Serial Terminal or PC Running Terminal Emulator Software
  - Programming Cable

#### Communications Protocol for Serial Terminal

baud rate	1200
data bits	8
parity	none
stop bits	1
local echo	on

- Turn the power switch to the OFF position
- Connect the programming cable between the ML-100 and the vehicle connector
- Connect the DB9 connector to the serial terminal
- Turn the Application Rate control fully Counter Clockwise
- Turn on the power for the serial terminal and the ML-100

### TO CHECK VERSION NUMBER OF SOFTWARE

- Press 'v' then ENTER
- The screen will display 'V' then the software version number

### TO CHANGE THE FREQUENCY SETTING

- The frequency is factory set at 50 Hertz
- Pressing 'f' then ENTER will display the current frequency
- Set the frequency according to valve manufacturers specifications.
- Many proportional valves will operate as well or better at frequencies less than the manufacturers specification.

Press 'f' then the desired frequency in Hertz (30 - 180), then ENTER

#### TO ADJUST THE VALVE TRIM

The valve trims are factory set at 15% (min) and 95% (max). You will likely need to reset them.

Make sure the hydraulic system is running and completely warmed up. Since the DC resistance of the typical proportional valve coil changes with temperature it should be at its normal operating temperature when making valve trim adjustments.

First reset minimum and maximum valve trims to 2% and 98% respectively.

To do this press 'm' then '2' then ENTER, the screen will display 'M2'

Then press 'x' then '9' then '8' then ENTER, the screen will display 'X98'

#### TO SET MINIMUM TRIM

Pressing 'm' then ENTER will display the current minimum duty cycle

Turn the Application Rate control until the valve just begins to flow oil (or when the shaft of the hydraulic motor just begins to turn).

Press 'd' then ENTER

The screen will display 'D' then the current duty cycle, the min should be set to this level

To set the min, press 'm' then the min duty cycle (found previously), then ENTER

#### TO SET MAXIMUM TRIM

Pressing 'x' then ENTER will display the current maximum duty cycle

Adjust the Application Rate control until the flow is maximized, but try not to set the max too high. Overdriving the coil will cause unwanted heating.

Press 'd' then ENTER

The screen will display 'D' then the current duty cycle, the max should be set to this level

To set the max press 'x' then the max duty cycle (found previously), then ENTER

#### TO CHANGE ZERO ENABLE

If the zero enable feature is disabled the ML-100 will operate at the min trim level when the Application Rate control is fully counter-clockwise

If the zero enable feature is enabled the ML-100 will be OFF when the Application Rate control is

fully counter\_clockwise

Pressing 'z' then ENTER will display the status of the zero enable feature: Z1 = enabled, Z0 = disabled

To enable, press 'z' then '1' then ENTER.

If you wish to disable this feature press 'z' then '0' then ENTER.

If this feature is disabled the output will be at the previously set min level when the Application Rate control is fully Counter\_Clockwise. The ML-100 is shipped with this feature enabled.

#### TO CHECK THE SOFTWARE VERSION

Pressing 'v' then ENTER will display the current software version

#### FUSE REPLACEMENT

Disconnect the connector from the back of the unit

Remove the four screws fastening the front plate to the enclosure

Remove the faceplate

Grasp the fuse (red component protruding from board mounted to enclosure) and remove

Replace with 10 Amp automotive style (ATO) fuse

### 9 Pin Round Connector pin out

- 1 not connected
- 2 Valve (+)
- 3 Valve (-)
- 4 Serial Data Receive
- 5 Switched Power
- 6 Power in (+12V)
- 7 Serial Data Transmit
- 8 Low Level Signal
- 9 Ground

## PROGRAMMING CABLE FOR ML-100

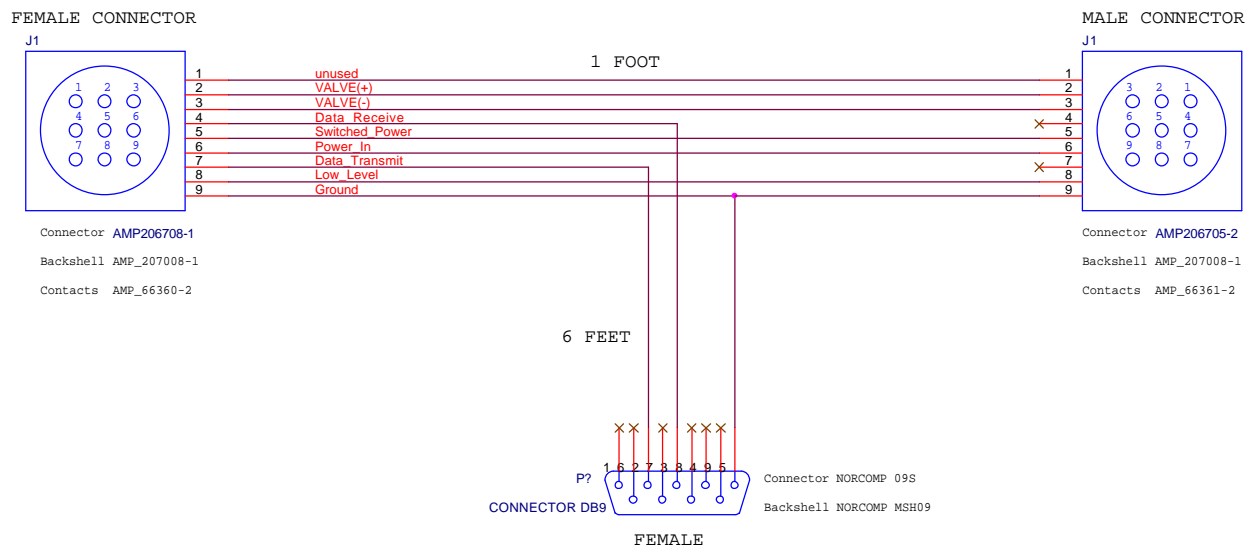

## VEHICLE CONNECTIONS

